

Part #	Description
8 – 1	Saw Base
8 – 2	Handle Mount
8 – 3	Powerhead Pivot Plate Bearing
8 – 4	Wheel
8 – 5	Powerhead Pivot Plate
8 – 6	Powerhead Plate Alignment
8 – 7	Powerhead Plate Lock
8 – 8	Front Wheel Mount
8 – 9	Pointer Arm
8 – 10	Pointer
8 – 11	Depth Stop
8 – 12	Wrench Holder
8 – 13	Nut Wrench

Part #	Description
8 – 14	Shaft Wrench
8 – 15	Handle
8 – 16	Grip
8 – 17	Blade Holder
8 – 18	Lift/Lower Lock
8 – 19	Position Lock Nut
8 – 20	4-arm Knob
8 – 21	Tension Spring

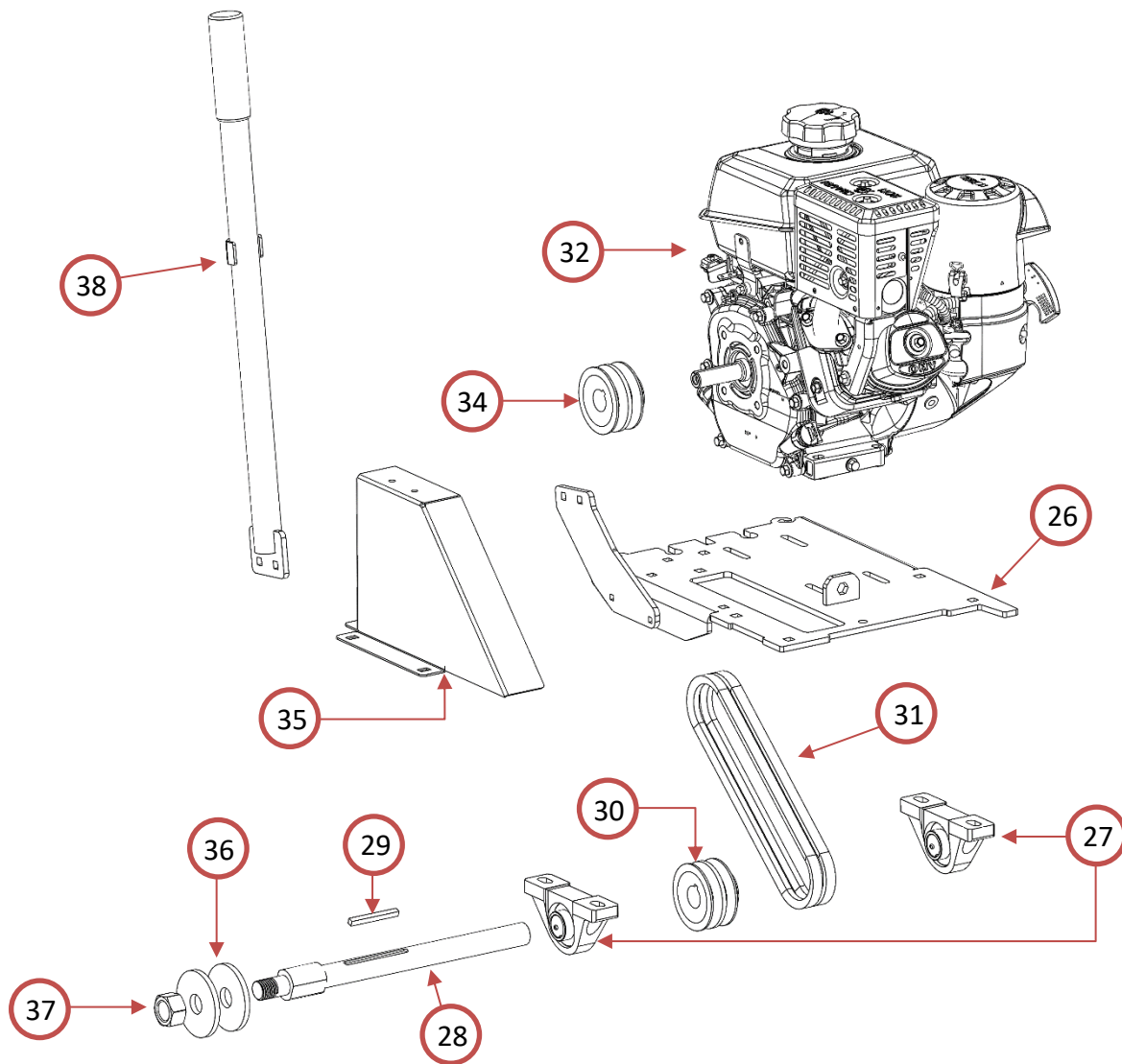

Part #	Description
8 – 26	Powerhead Mounting plate
8 – 27	Blade Shaft Bearing
8 – 28	Blade Shaft
8 – 29	Blade Shaft Key
8 – 30	Blade Shaft Pulley
8 – 31	Drive Belt
8 – 32	Motor
8 – 33	Motor Shaft Key
8 – 34	Motor Pulley
8 – 35	Belt Cover
8 – 36	Blade Clamp
8 – 37	Blade Shaft Nut
8 – 38	Lift/Lower Handle
8 – 40	Shaft Assembly (Part #: 27, 28, 29, 30, 36 & 37)
8 – 41	Blade Clamp Shim ( Not Pictured )

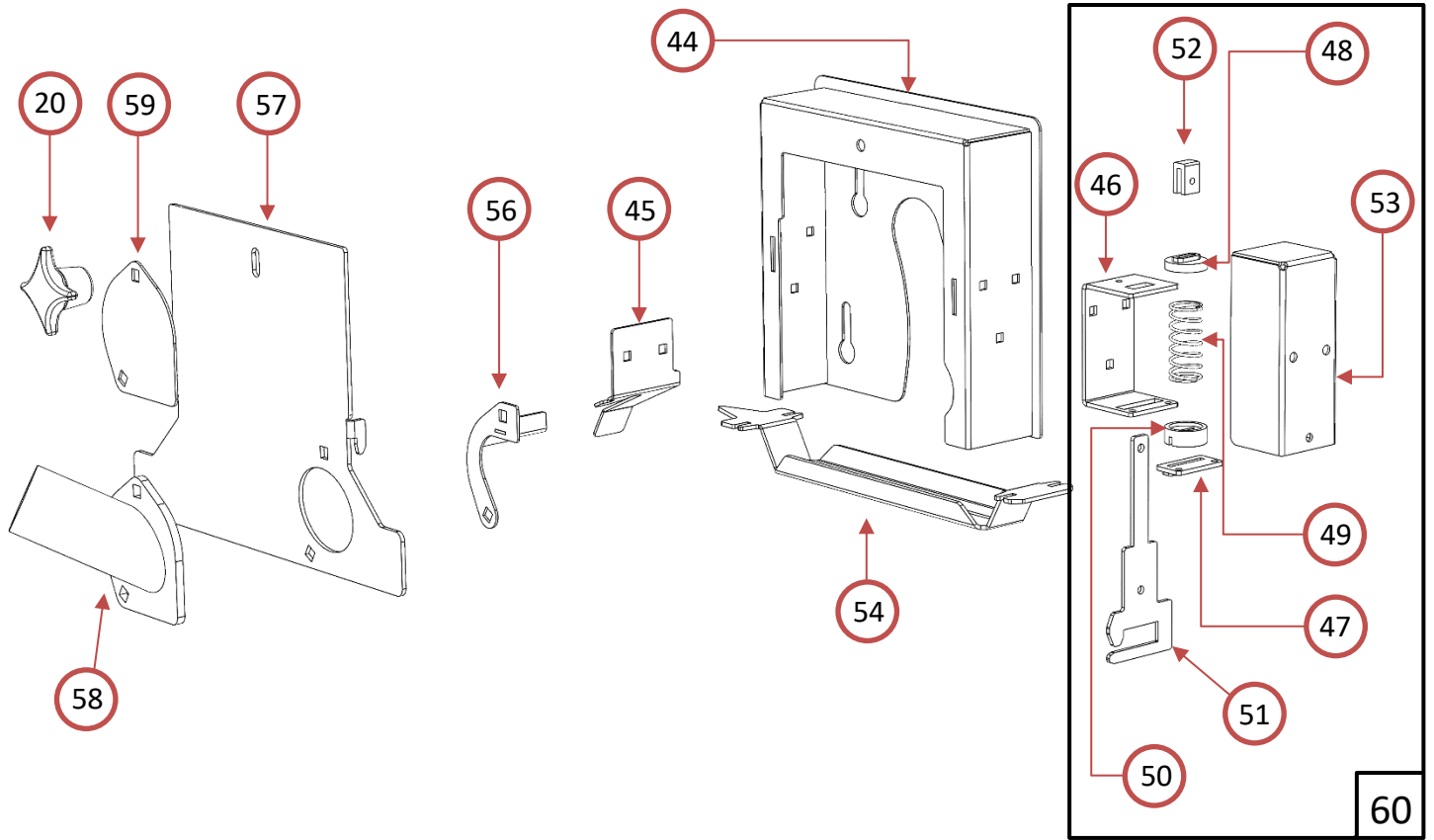

Part #	Description
8 – 44	Dust Box Main
8 – 45	Internal Dust Deflector
8 – 46	Spring Mount
8 – 47	Lower Slide
8 – 48	Upper Spring Retainer
8 – 49	Spring
8 – 50	Lower Spring Retainer
8 – 51	Skid Plate Slide
8 – 52	Slide Stop
8 – 53	Spring Cover
8 – 54	Skid Plate - 0.090 Opening
8 – 55	Skid Plate - 0.25 opening (Not Pictured)
8 – 56	Dust Box Door Baffle
8 – 57	8EE Dust Box Door
8 – 58	Dust port
8 – 59	Dust port Block Off
8 – 60	Skid Plate Slide Assembly
8 – 61	Early Entry Dust Box Assembly w/ Skid Plate

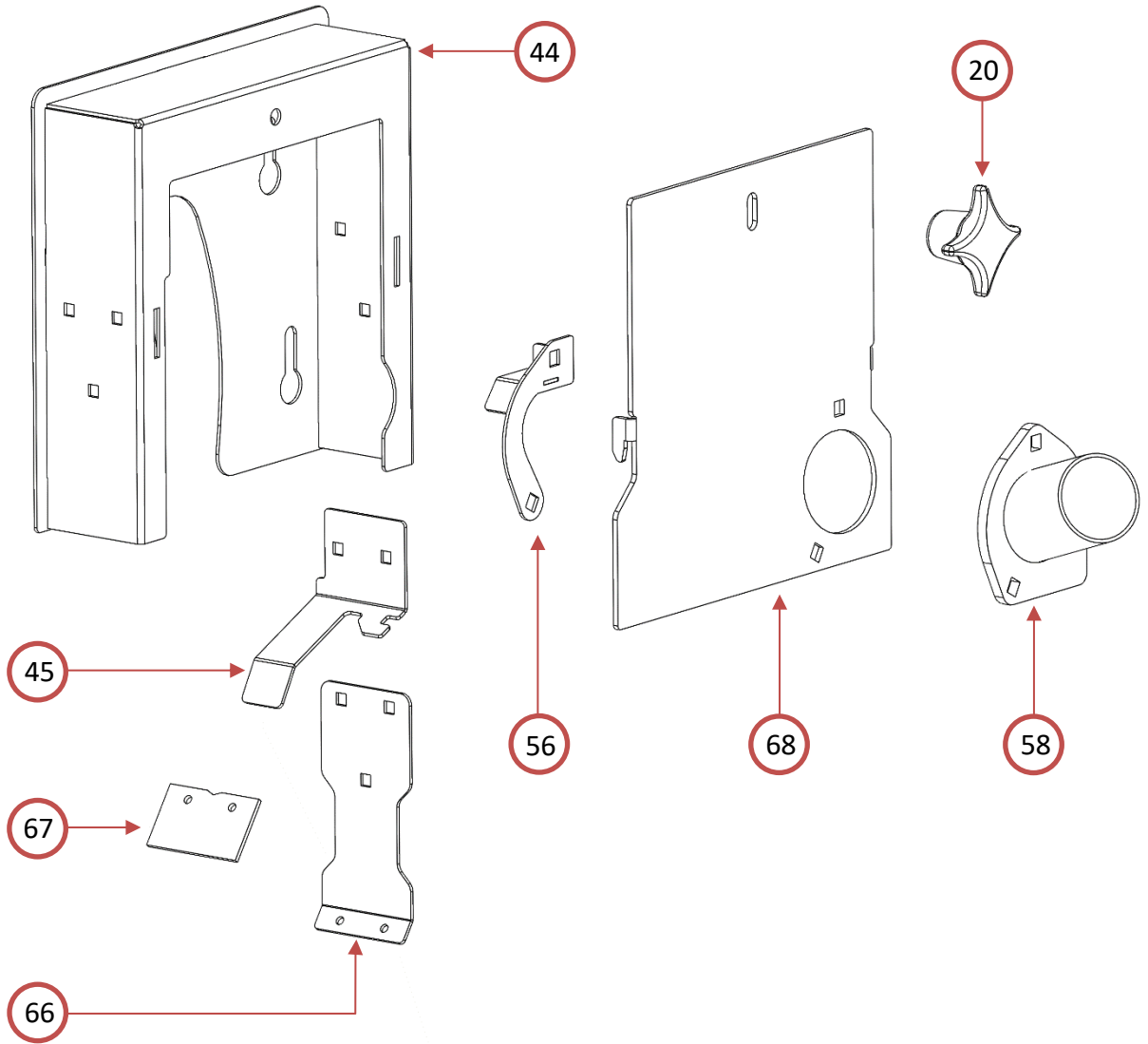

Part #	Description
8 – 66	Dust Skirt Mount
8 – 67	Dust Skirt
8 – 68	GCT-8 Series II Dust Box Door
8 – 69	GCT-8 Series II Dust Box Assembly