

GorillaConcreteTools

GS-100 Early Entry

Product Manual



Parts Diagram

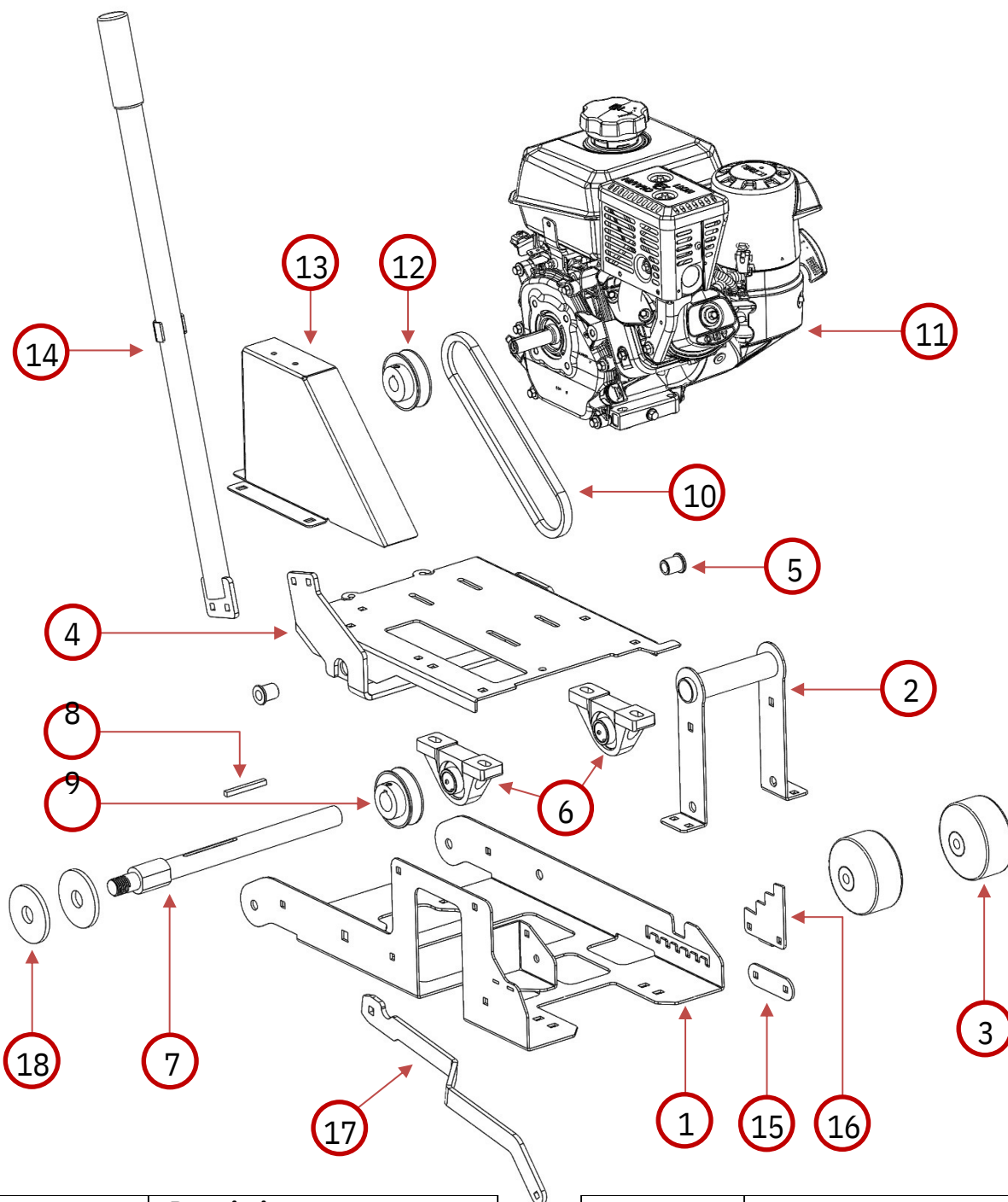

Part Number	Description
GS100 - 1	Saw Base
GS100 - 2	Front Wheel Mount
GS100 - 3	4" Saw Wheel
GS100 - 4	Motor Plate
GS100 - 5	Motor Plate Bushing
GS100 - 6	Blade Shaft Bearing
GS100 - 7	Blade Shaft
GS100 - 8	Blade Shaft Key
GS100 - 8	Blade Shaft Pulley
GS100 - 9	Drive Belt

GS100 - 11	Engine
GS100 - 12	Drive Pulley
GS100 - 13	Belt Cover
GS100 - 14	Lift/Lower Handle
GS100 - 15	Depth Stop Backer
GS100 - 16	Depth Stop
GS100 - 17	Pointer Arm
GS100 - 18	Blade Clamp
GS100 - 19	Blade Shaft Nut
GS100 - 20	Engine Shaft Key

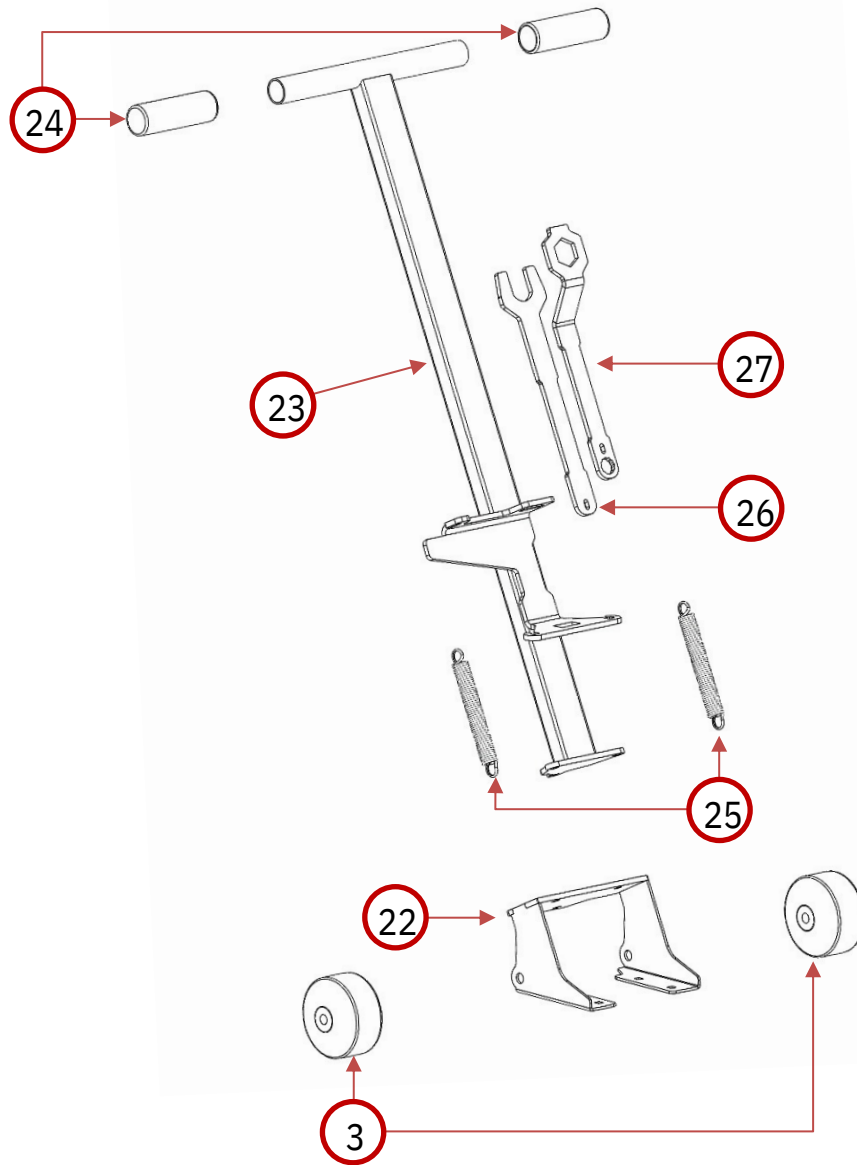

Part Number	Description
GS100 – 22	Handle Mount
GS100 – 23	Saw Handle
GS100 – 24	Handle Grip
GS100 – 25	Motor Plate Tension Spring
GS100 – 26	Blade Shaft Wrench
GS100 – 27	Blade Nut Wrench

GS-100 Early Entry Dust Box

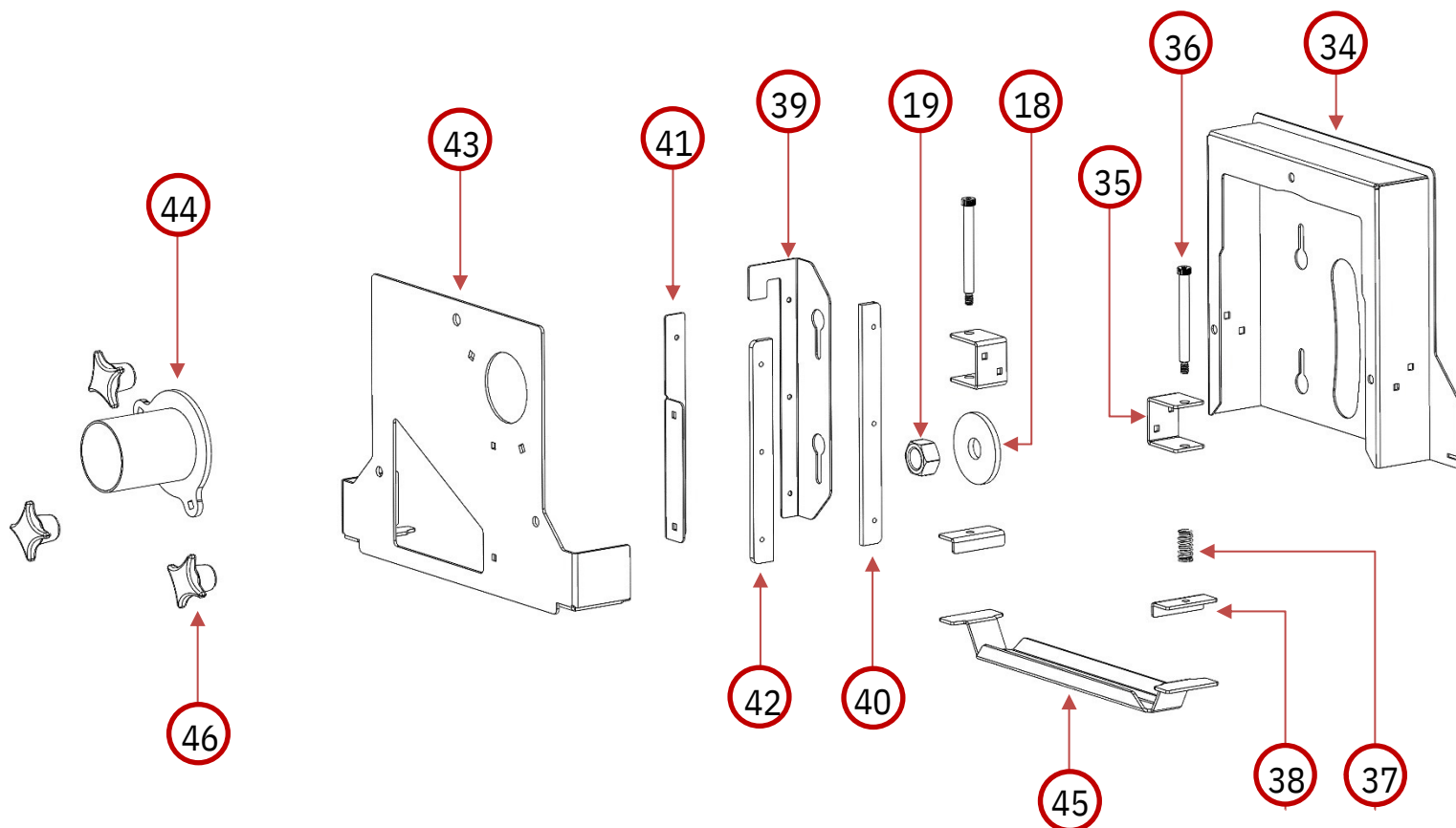

Part Number	Description
GS100 - 34	Dust Box
GS100 - 35	Tensioner Slide Mount
GS100 - 36	Tensioner Slide
GS100 - 37	Skid Plate Tensioning Spring
GS100 - 38	Skid Plate Tensioner
GS100 - 39	Dust Box Internal Baffle
GS100 - 40	Internal Baffle Plate
GS100 - 41	Dust Box Door Baffle
GS100 - 42	Door Baffle Plate
GS100 - 43	Dust Box Door
GS100 - 44	Dust Port
GS100 - 45	Skid Plate
GS100 - 46	4-arm knob
GS100 - 47	Dust Port Block Off Plate (not pictured)
GS100 - 48	Complete Dust Box Assembly